

AT HOME LEARNING

Week 7 GRAPH THE WEATHER! COLOR & READ YOUR ABC BOOK!

Monday - Weather

Reading Read a book about weather. Pretend to read the book upside down and backwards. Have them show you how to do it.	Letters & Sounds "Cloud writing". Place shaving cream in a tray or baking pan. Write letters with their finger.	Math Number Dot It! Use clouds to cover the board (aka cotton balls).
Fine Motor Draw or fingerprint a rainbow.	Art or Sensory Make a rain stick. Use a cardboard tube. Tape one end and place rice and sticks inside. Tape the other end and decorate with markers.	Science Go or look outside to see what the weather is and graph it on your weather graph. Remember to do this everyday.

Tuesday - The Beach

Reading Read a book about the beach or beach animals. Who are the characters in the book?	Letters & Sounds Pretend you are at the beach and lay on a beach towel. Play the Clap and Build Syllables game.	Math Find 5 ocean animal figures. Measure each animal with crayons. Line the crayons up to make a ruler. Count how many long each animal is.
Fine Motor Draw beach waves on a piece of paper. Trace the lines with various shades of blue marker and crayon.	Art or Sensory Make a beach sensory tub. Place sand or Kinetic sand in a plastic tub. Wet the sand and make sandcastles. Add seashells.	Science Make a sensory bottle. See recipe page for directions.

Wednesday - Camping

Reading Read a book about camping or nature. Predict what is this book going to be about?	Letters & Sounds Play letter or sound Dot It. Use mini marshmallows to cover the spots.	Math Go on a rock hunt. Sort the rocks by size using the sorting board. Which has the most/least?
Fine Motor Make a trail mix necklace. Lace circle cereal and mini pretzels on a string or pipe cleaner. Eat it when you are finished!	Art or Sensory Campfire art! Cut small strips of brown paper. Draw the fire or finger paint it with red, yellow, and orange.	STEM Put up a tent or fort outside. Camp, sing songs, and have a picnic.

PLAY IS THE HIGHEST FORM OF RESEARCH. – ALBERT EINSTEIN

AT HOME LEARNING

WEEK 7 GRAPH THE WEATHER! COLOR & READ YOUR ABC BOOK!

THURSDAY - PLANTS

<p>Reading Read a book about plants. Is it a fiction or non-fiction book? How do you know?</p>	<p>Letters & Sounds Make a list of the parts of a plant (stem, leaf, flower). What is the first sound in each word?</p>	<p>Math Collect leaves, petals, and stems/sticks. Sort the leaves various ways. Make shapes with the objects.</p>
<p>Fine Motor Collect leaves and petals. Use a hole punch to make holes in each one. Lace a piece of string through the holes.</p>	<p>Art or Sensory Paint with flowers. Put the flowers in paint and stamp them onto the paper.</p>	<p>Science Dissect a plant. Pull a weed. Point out the parts of a plant and what each part does.</p>

FRIDAY - LETTERS

<p>Reading Read an ABC book. Say the sound of each letter as you read.</p>	<p>Letters & Sounds Sort the letters using the sorting boards. Cut out the small letters. Sort the letters and glue them to the boards.</p>	<p>Math Make a list of everyone in your family. Count the number of letters in each person's name. Who has the most/least letters in their name?</p>
<p>Fine Motor Make a writing tray with a cake pan. Put sprinkles or salt in the bottom. Using your finger, write letters in the tray.</p>	<p>Art or Sensory Letter collage! Use the tiny letters or cut letters from magazines/ads and create a letter collage.</p>	<p>Gross Motor Make an obstacle course. Place letter cards along the way. Say the letters and sounds as you go through the course.</p>

APPS & WEBSITES TO TRY

<p>Raz-Kids Mini readers at various levels and offers Spanish and French too. (Free for 30 days) https://www.raz-kids.com/</p>	<p>Brain Pop Jr. Educational website with videos and activities about science, social studies, literacy, arts, and music. (Free for 30 days) https://jr.brainpop.com/</p>	<p>Starfall Learn about letters and sounds. </p>
---	---	--

YOUTUBE CHANNELS TO GET KIDS MOVING

<p>The Laurie Berkner Band YouTube Songs that teach and get kids moving!</p>	<p>Kid Boomers Kid Music Channel - YouTube Songs that teach and get kids moving!</p>	<p>Jack Hartman YouTube Fun songs that teach.</p>
---	---	--

SCIENCE SENSORY PLAY

SENSORY BOTTLES

Pick a sensory bottle or create your own! Sensory bottles can be very calming for children. Shake and watch it change and move!

What you Need:

- Clean, empty bottle (any water bottle, soda bottle, or sport drink bottle will work)
- Hot glue and tape for the top (any tape will work)
- Each bottle has different things inside. Look next to the bottle to see what you need to create it.

Volcano Sensory Bottle - vegetable oil, red food coloring, water

- Fill the bottle halfway with water and add red food coloring
- Fill to the top with vegetable oil
- Glue and tape the lid closed

Ocean Sensory Bottle - baby oil, blue food coloring, water

- Fill the bottle halfway with water and add blue food coloring
- Fill to the top with baby oil
- Glue and tape the lid closed

Bubbles Sensory Bottle - dish soap, food coloring, water

- Fill the bottle $\frac{3}{4}$ full with water
- Add 2tbl dish soap and food coloring to match the dish soap
- Glue and tape the lid closed

Traditional Sensory Bottle - clear glue, food coloring, water, glitter

- Fill the bottle halfway with water
- Add 1 cup clear glue
- Add food coloring and glitter
- Fill to the top with water
- Glue and tape the lid closed

Tiny Treasures Sensory Bottle - dry beans or rice, tiny toys (Lego people, gems, mini erasers, pom poms, or mini figures)

- Fill $\frac{1}{3}$ with dry beans or rice
- Add tiny treasures
- Fill $\frac{1}{3}$ with more dry beans or rice
- Add more tiny treasures
- Glue and tape the lid closed

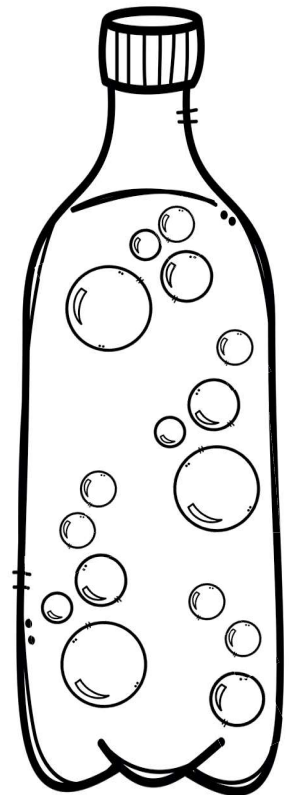

For even more sensory bottle ideas, check out
<https://pocketofpreschool.com/?s=sensorybottles>

My Alphabet Book

Name: _____

Aa

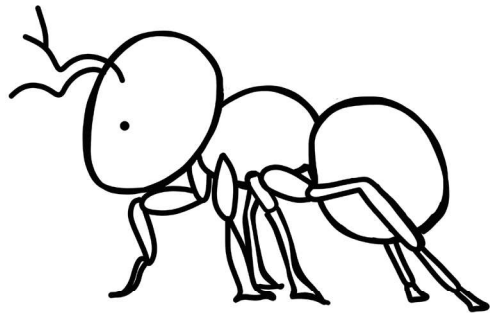

A is for ant.

Bb

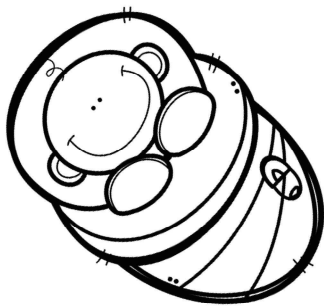

B is for baby.

Cc

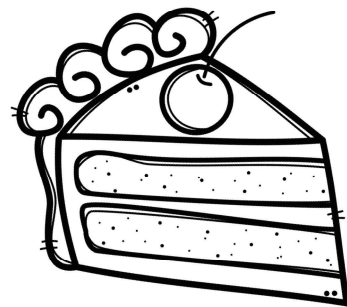

C is for cake.

Dd

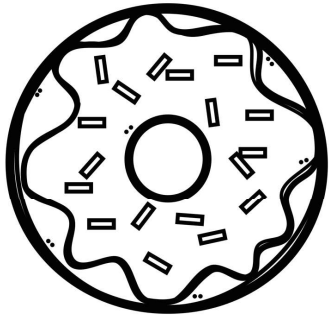

D is for donut.

Ee



E is for elf.

Ff

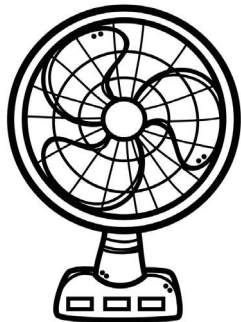

F is for fan.

Gg



G is for game.

H H

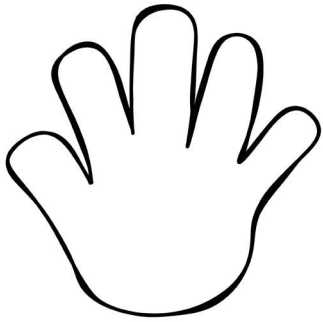

H is for hand.

I i

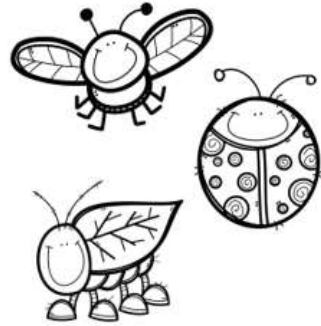

I is for insect.

J j

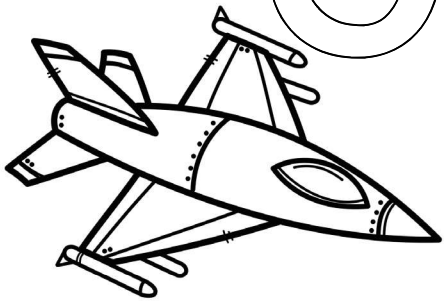

J is for jet.

K k

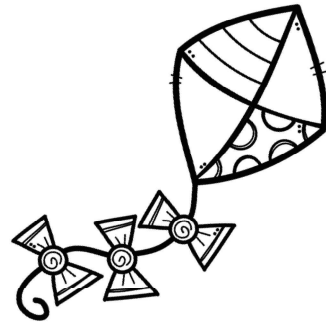

K is for kite.

L l

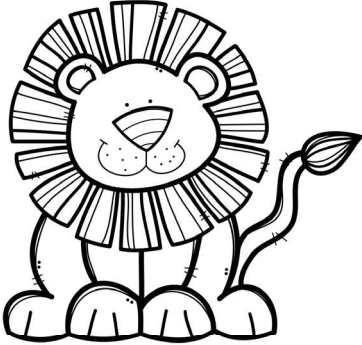

L is for lion.

M m

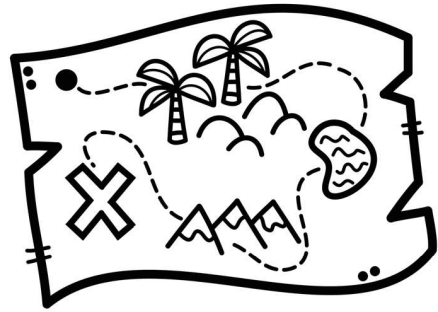

M is for map.

N n

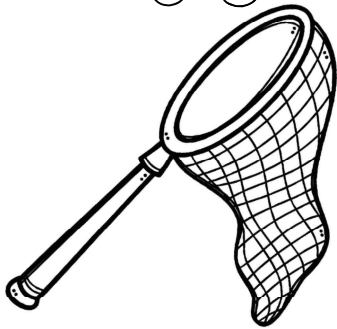

N is for net.

O o



O is for owl.

Pp

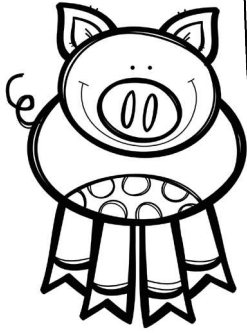

P is for pig.

Qq



Q is for queen.

Rr



R is for rain.

Ss

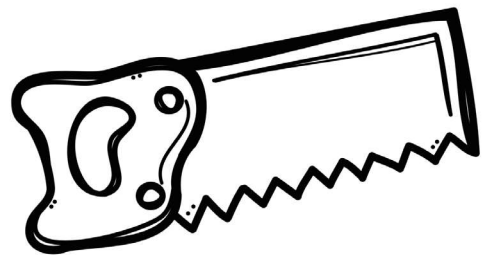

S is for saw.

T t

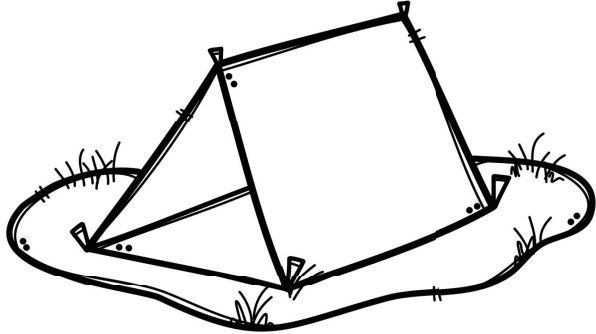

T is for tent.

U u

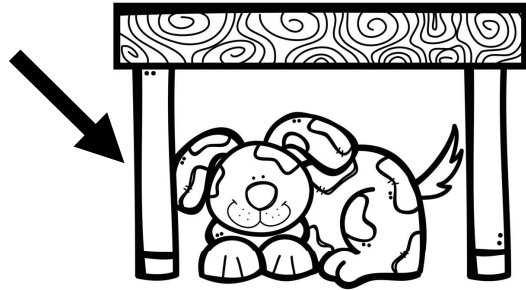

U is for under.

V v

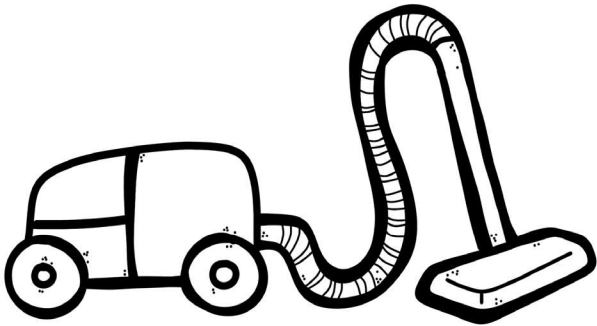

V is for vacuum.

W w

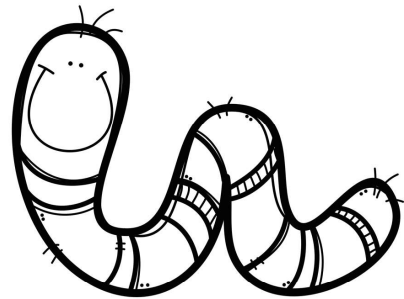

W is for worm.

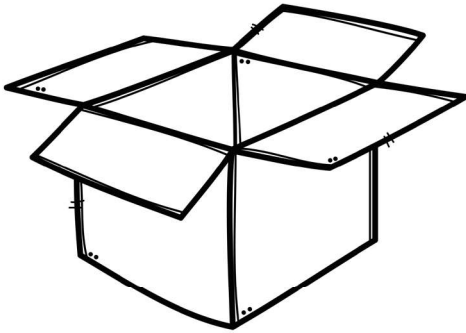
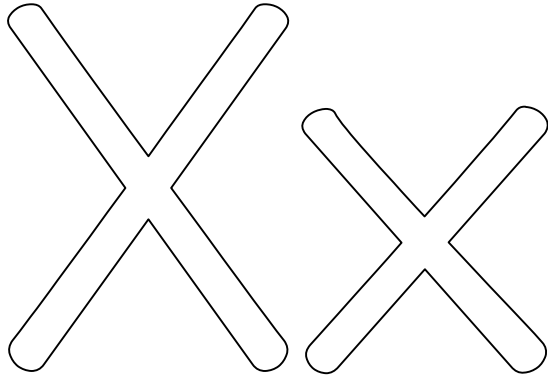

X is for box.

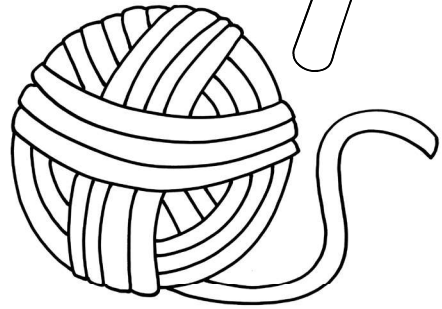
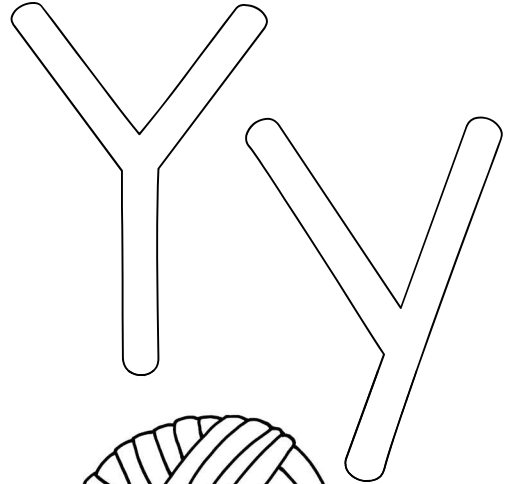

Y is for yarn.

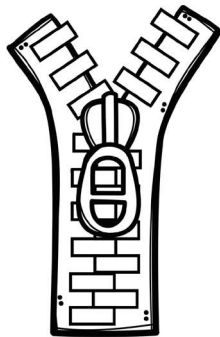
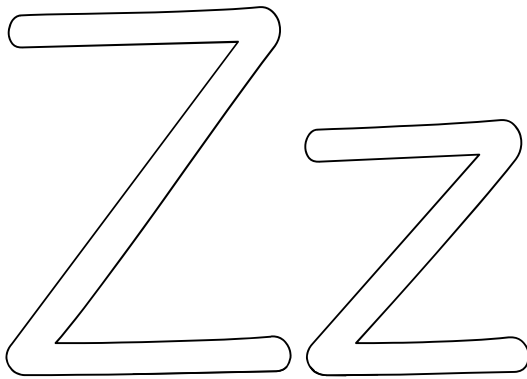

Z is for zip.

bus

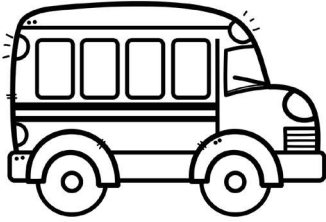

monkey

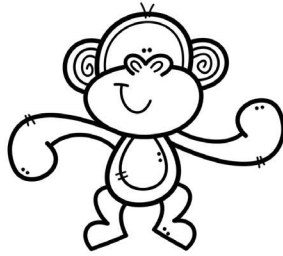

elephant

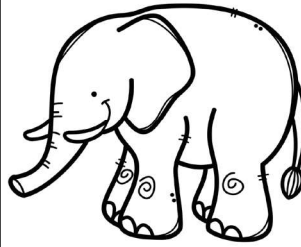

sailboat

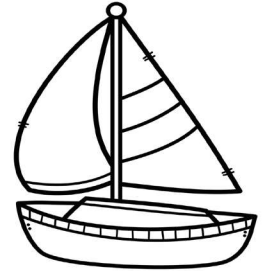

banana

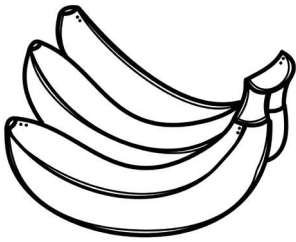

rhinoceros

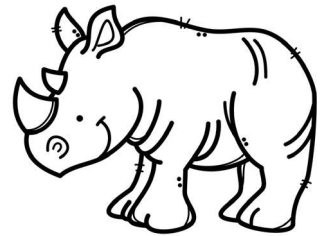

motorcycle

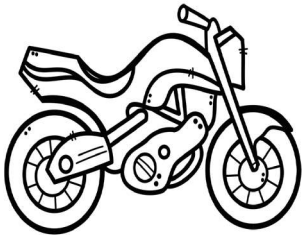

snake

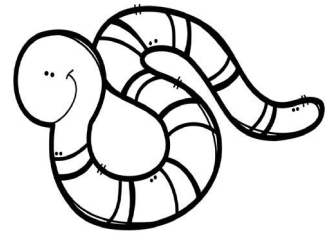

turtle

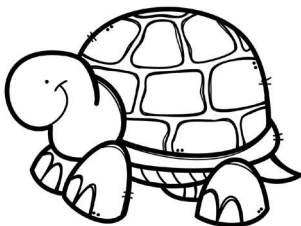

Clap & Build the Syllables

Point to an object, clap the number of syllables, and build a tower using blocks or Legos for each syllable.

submarine

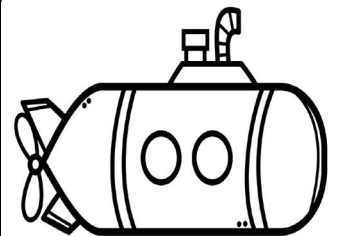

strawberry

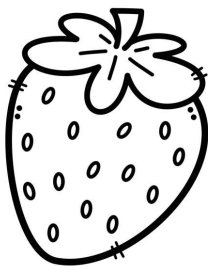

bike

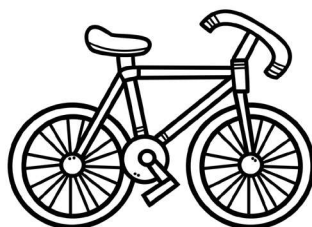

alligator

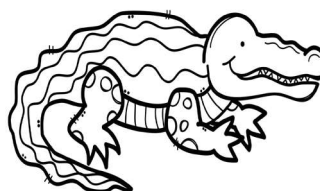

pretzel

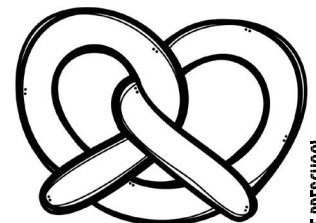

Letter Sort

**UPPERCASE
LETTERS**

**lowercase
letters**

Letter Sort



in my name



~~NOT~~ in my name

A	B	C	D	E	F	G	H
I	J	K	L	M	N	O	P
Q	R	S	T	U	V	W	X
Y	Z	a	b	c	d	e	f
g	h	i	j	k	l	m	n
o	p	q	r	s	t	u	v
w	x	y	z	Cut apart to create collage letters!			

A	B	C	D	E	F	G	H
I	J	K	L	M	N	O	P
Q	R	S	T	U	V	W	X
Y	Z	a	b	c	d	e	f
g	h	i	j	k	l	m	n
o	p	q	r	s	t	u	v
w	x	y	z	Cut apart to create collage letters!			

Letter Dot It

Point to a letter, say the letter name and sound. Dot with a dot marker, cover with a sticker, trace the letter, or color the letter dot.

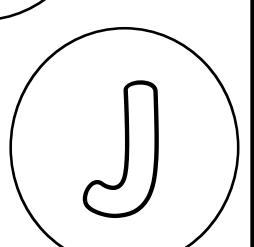
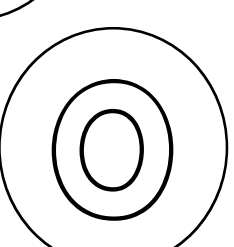
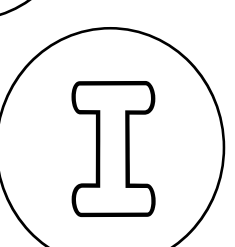
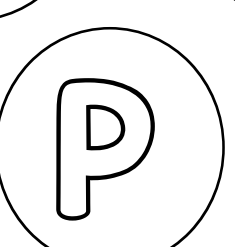
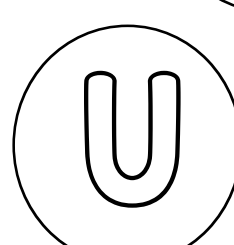
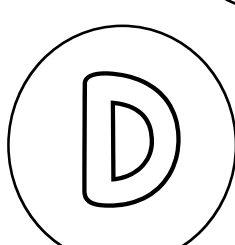
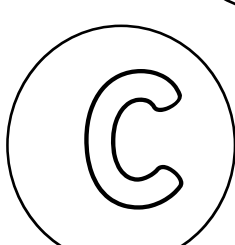
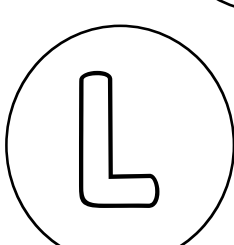
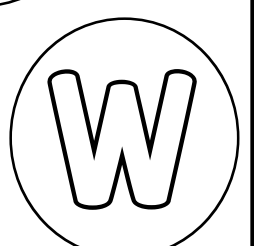
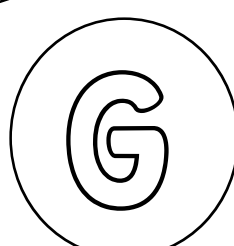
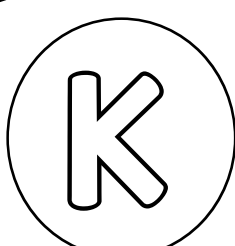
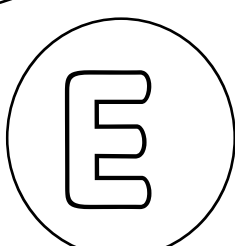
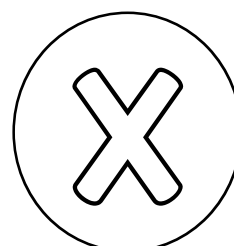
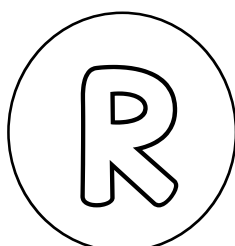
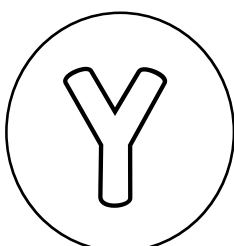
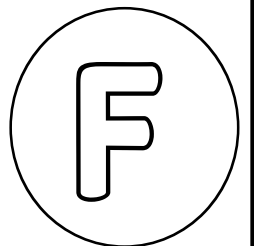
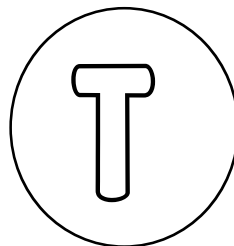
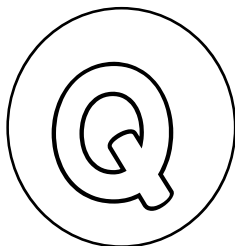
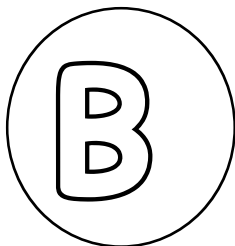
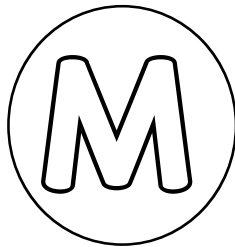
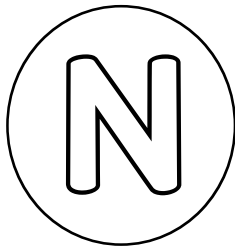
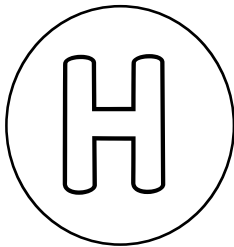
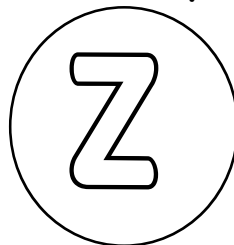
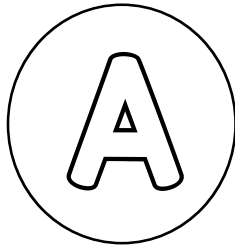
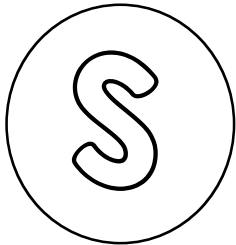

Letter Dot It

Point to a letter, say the letter name and sound. Dot with a dot marker, cover with a sticker, trace the letter, or color the letter dot.

Star

s a z j

h n m u

b q t f

y v r x

Star

e k g w

l c d

p i o

Star



Letter Dot It

Point to a letter, say the letter name and sound. Dot with a dot marker, cover with a sticker, trace the letter, or color the letter dot.

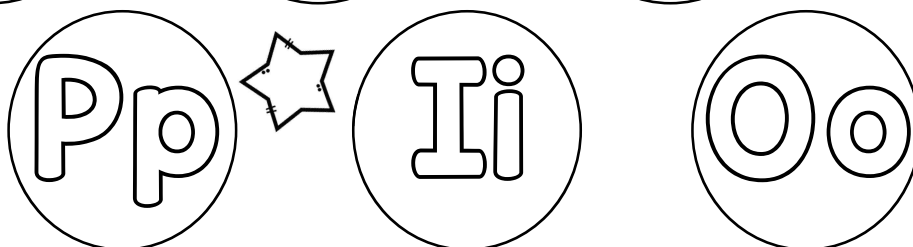
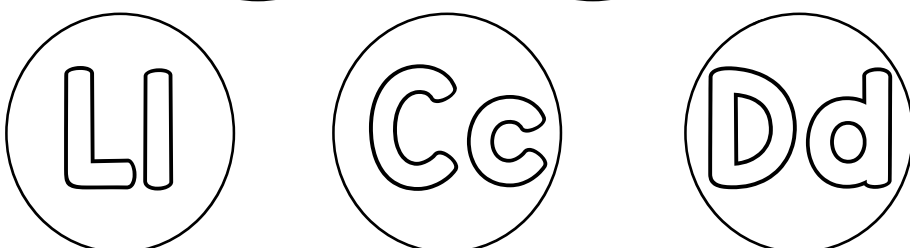
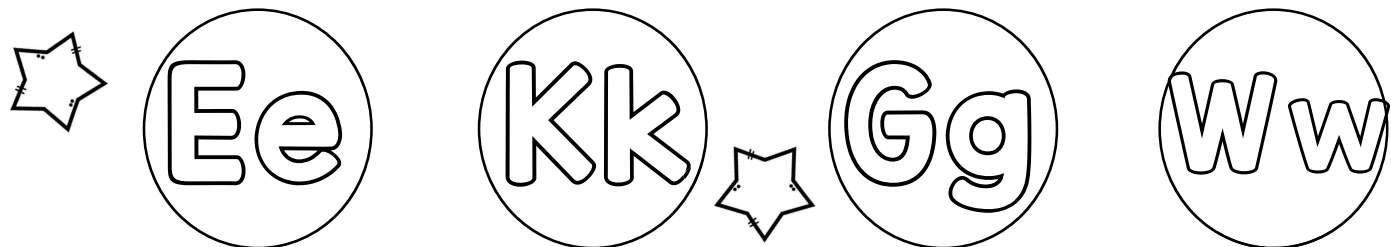
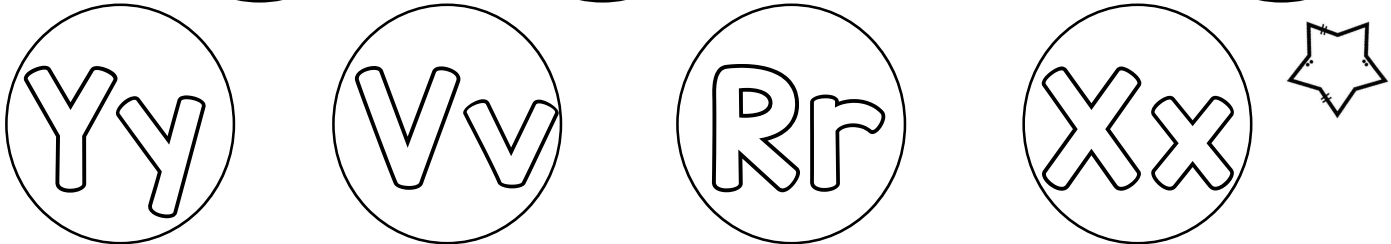
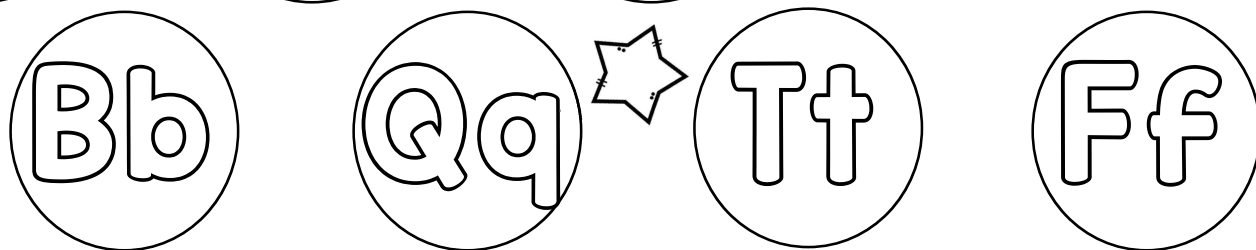
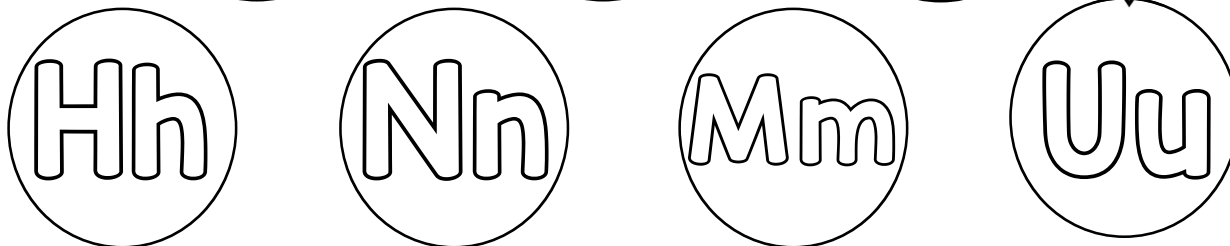
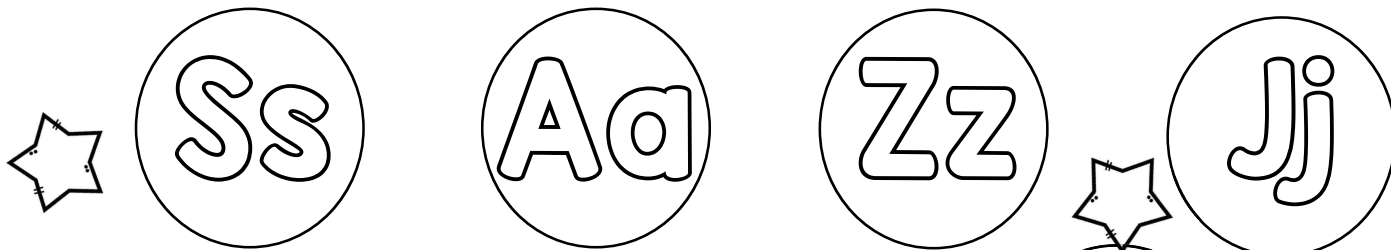

Sound Dot It

Point to an object, say the beginning sound. Write the letter in the dot.



Size Sort

small

medium

large

Number Dot It

Point and say the number. Dot the number with a dot marker, trace the number, or color the number dot.

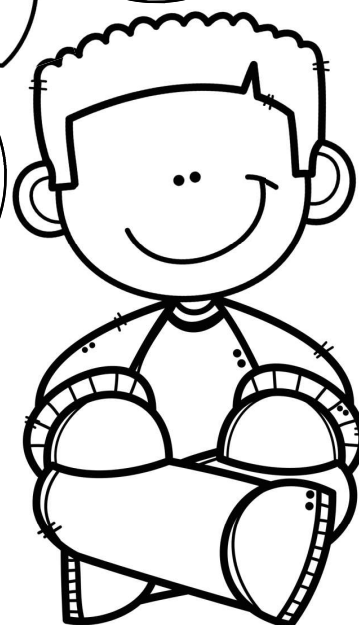
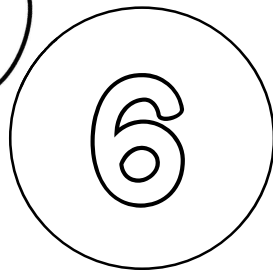
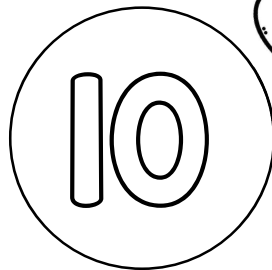
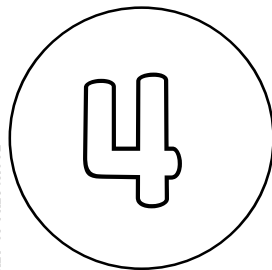
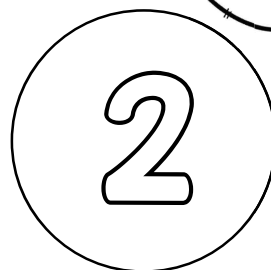
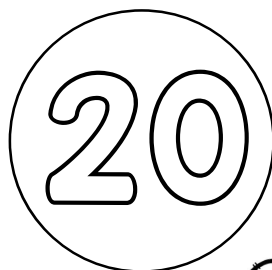
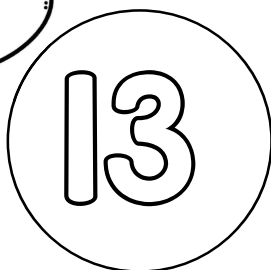
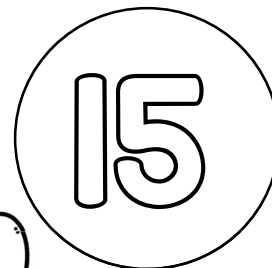
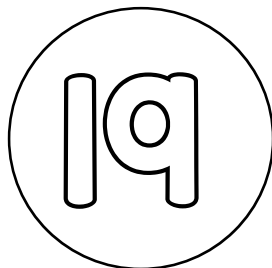
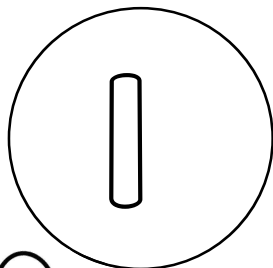
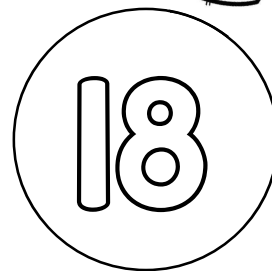
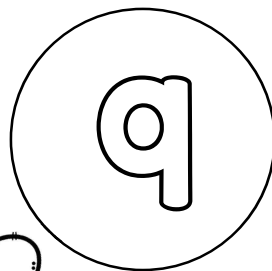
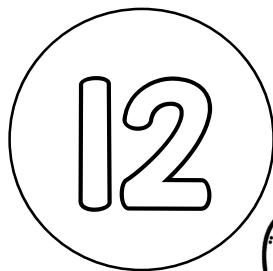
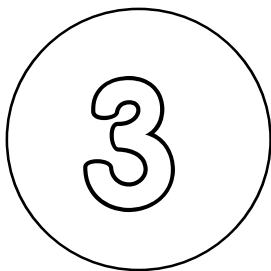
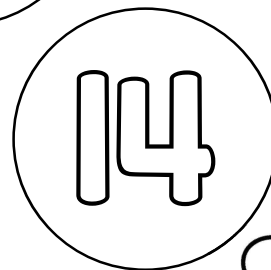
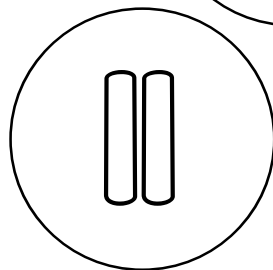
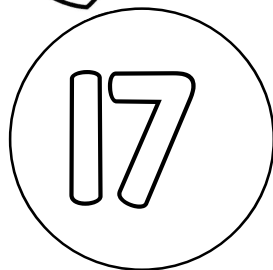
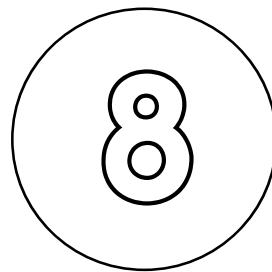
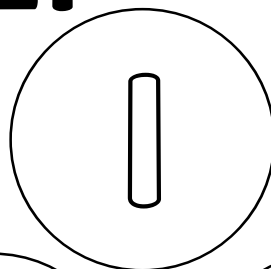

Number Dot It

Point and say the number. Dot the number with a dot marker, trace the number, or color the number dot.

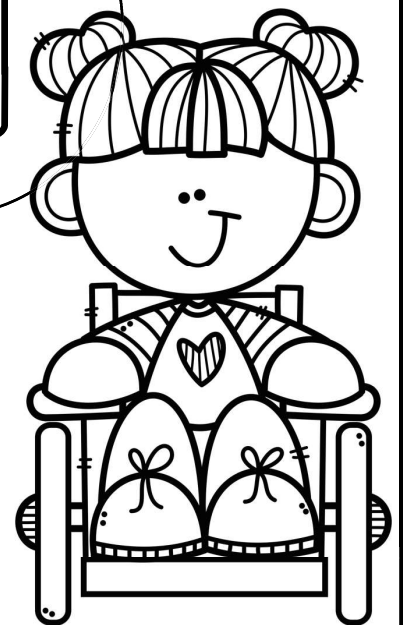
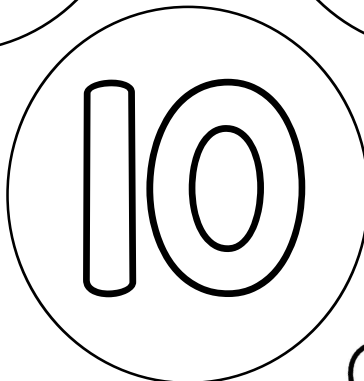
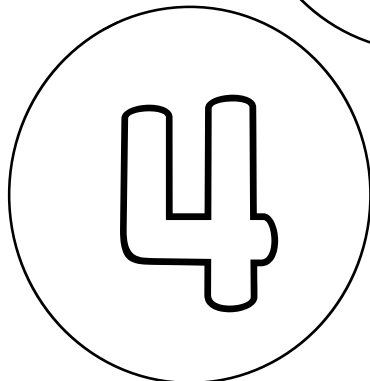
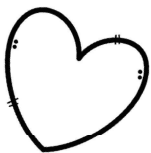
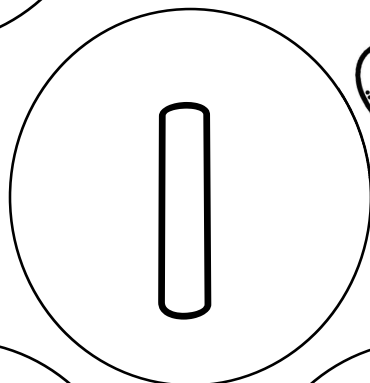
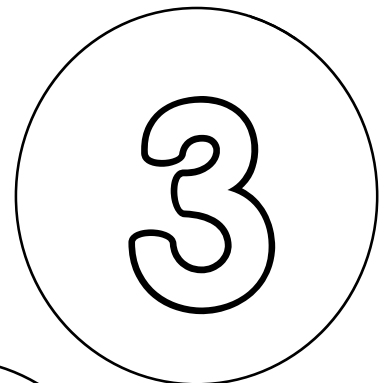
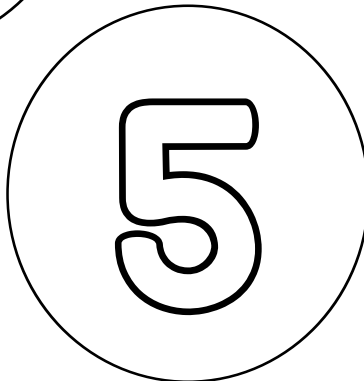
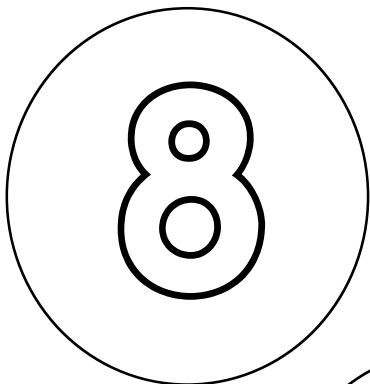
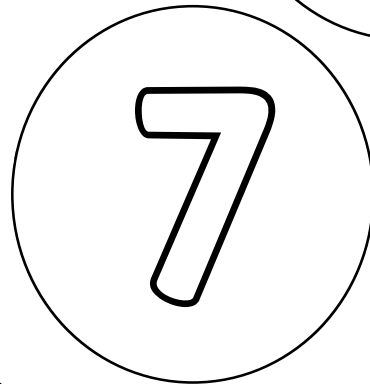
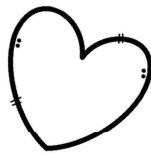
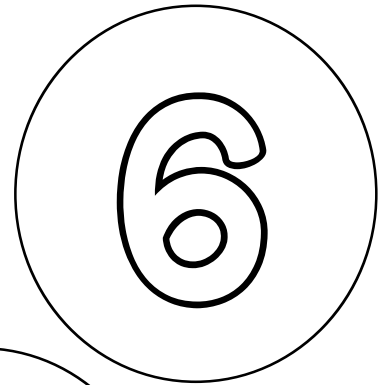

1

2

3

4

5

6

7

8

9

10

Number Card Games:

- Hi/Low (aka War)
- Memory
- Hide around the house
- Matching
- Build a block tower on top of the number

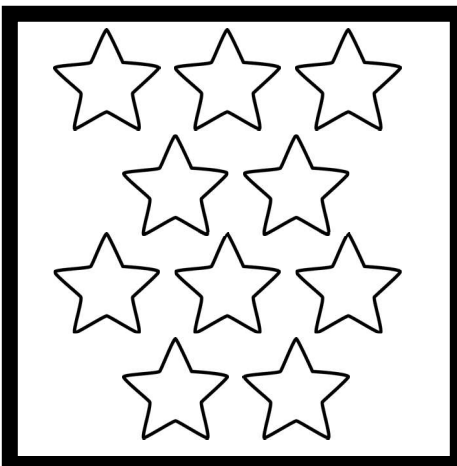
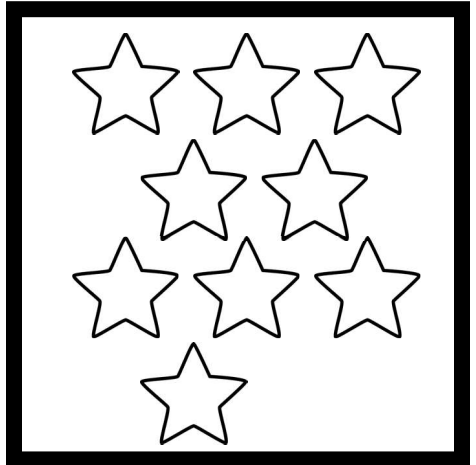
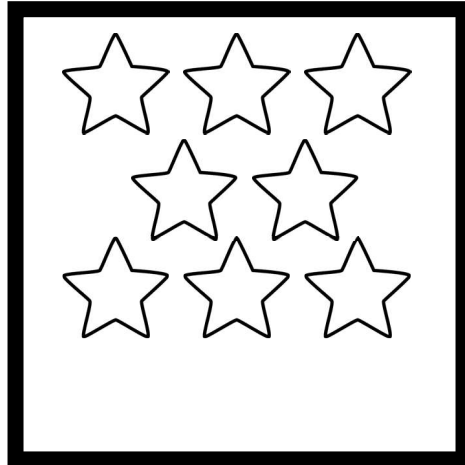
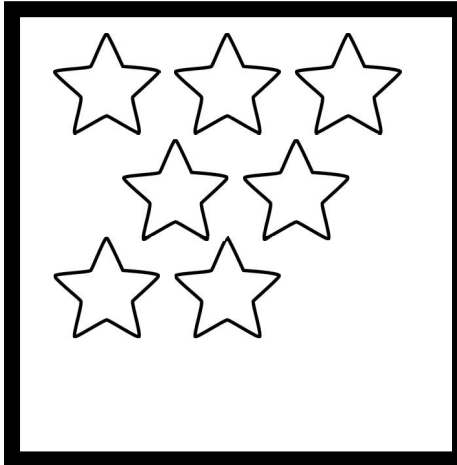
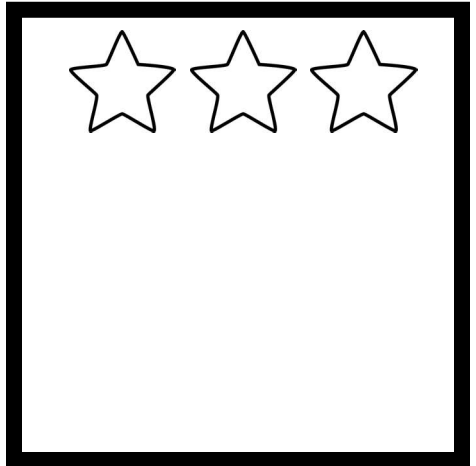
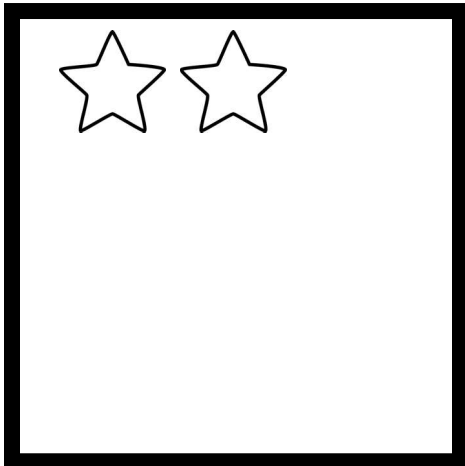
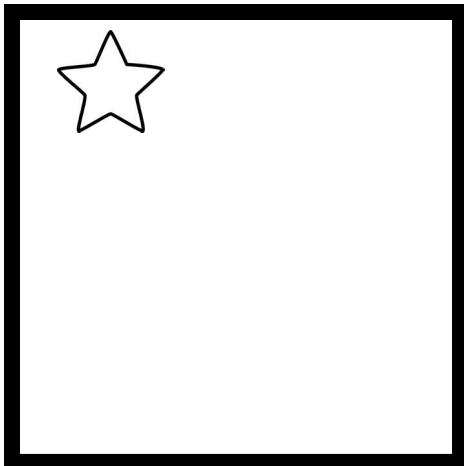

Number Card Games:

- **Hi/Low (aka War)**
- **Memory**
- **Hide around the house**
- **Matching**
- **Build a block tower on top of the number**